



EIU
FOR THE
WALTER ENGINE

OPERATIONAL &
INSTALL MANUAL

Updated: 29 June 2016

Copyright 2016 by VR Avionics

© 2016 VR Avionics Inc.

All rights reserved.

This User and Installation Guide and the information contained herein is the proprietary data of VR Avionics. No part of this manual may be reproduced, copied, transmitted, disseminated or stored in any storage medium, for any purpose without the express written permission of VR Avionics, Inc. VR Avionics hereby grants permission to download a single copy of this manual and of any revision to this manual onto a hard drive or other electronic storage medium to be viewed for personal use, provided that such electronic or printed copy of this manual or revision must contain the complete text of this copyright notice and provided further that any unauthorized commercial distribution of this manual or any revision hereto is strictly prohibited. Information in this document is subject to change without notice. VR Avionics reserves the right to change or improve its products and to make changes in the content without obligation to notify any person or organization of such changes. Visit the VR Avionics website (www.vravionics.com) for current updates and supplemental information concerning the use and operation of this and other VR Avionics products.

VR Avionics

www.vravionics.com

Contents

Introduction.....	5
System Options.....	5
EIU versions.....	5
Operation.....	6
Introduction.....	6
Three Temperatures.....	7
Three Pressures.....	7
Two Speeds.....	7
One Fuel Flow.....	7
Four Fuel Quantities.....	7
One Voltage and Current.....	7
Eight Annunciation Switches.....	7
Serial Protocol.....	8
Installation.....	10
Tools and Equipment.....	10
Electrical Installation.....	11
Power, Ground and Serial Output.....	12
Voltage and Current Sensing.....	12
Fuel Quantities.....	13
Fuel Flow.....	14
Temperatures.....	14
Pressures.....	15
Speeds.....	16
Annunciation Switches.....	16
Pin Assignments.....	17
Configuration.....	18
Introduction.....	18
Configuration Settings.....	18
Temperature Calibration Offset.....	18
Temperature Calibration Span.....	18
Voltage Calibration.....	18
Shunt Rating.....	18
Shunt Positive Current Calibration.....	18
Shunt Negative Current Calibration.....	18
P1 Pressure Transducer Rating.....	18
P1 Pressure Calibration.....	18
P2 Pressure Transducer Rating.....	19
P2 Pressure Calibration.....	19
P3 Pressure Transducer Rating.....	19
P3 Pressure Calibration.....	19
N1 Speed Calibration.....	19
N2 Speed Calibration.....	19
Fuel Flow K-factor.....	19
Fuel Flow Filter Setting.....	19
Fuel Flow Sensor Type.....	19
Fuel Level x Sensor Type.....	19
Fuel Level x Calibration Offset, Interval and last interval.....	19
Fuel Level x Calibration Points.....	20
Fuel Level Designation RS232.....	20
SetView Software	21
Introduction.....	21
System Requirements.....	21
SetView download and Installation.....	21
Using SetView.....	21
Viewing and recording parameters.....	22

Synchronizing with the system.....	22
Sharing files via email.....	22
Adjusting the Configuration.....	23
Calibrating Fuel Tank Levels.....	24

Introduction

This manual describes the installation and operation of the Engine Information Unit (EIU) when used with a Walter/GE M601 engine. It similarly supports other gas-turbine engines.

System Options

The EIU can work standalone or be part of a larger VRX-M601 system, in which case this manual must be read in conjunction with our VRX-M601 Operational & Installation manual. The diagram below shows how functionality may be further expanded.

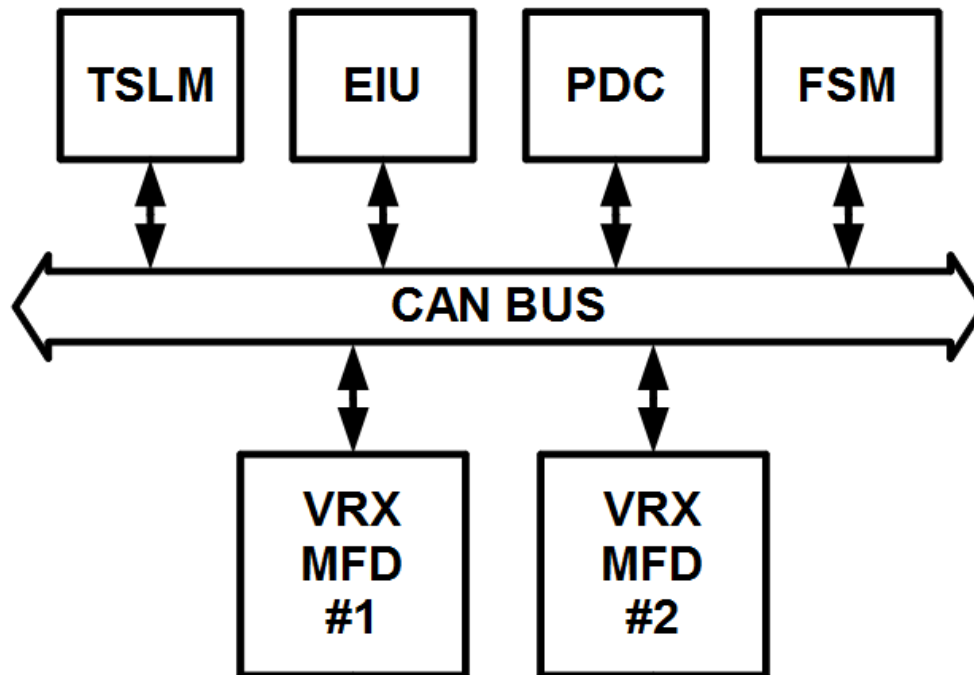

EIU versions

Two versions of the EIU have been produced over the years. The latter version have remained backward compatible with the earlier one with the exact same connector pin-out and functionality. The following table lists the basic differences as referenced by unit serial number:

Serial number range	Differences
1001 - 1039	First Generation, uses EIU Link interface program.
1040 and later	Uses our SetView program to setup the EIU.

Operation

Introduction

The Engine Information Unit (EIU) gathers data by reading various sensors both in-front-of and behind the aircraft's firewall and sends the parameter information via RS-232 (see [Serial Protocol](#)) and CAN interfaces to cockpit displays (EFIS), flight-recorders (black-boxes) and telemetry systems.

EIU measurements include:

- ➔ **Three Temperatures** using standard K-type thermocouple probes. These are used for inter-turbine temperature (ITT), oil-temperature and outside air temperature (OAT).
- ➔ **Three Pressures** using standard 4-20mA pressure transducers. These are used for torque, oil-pressure and fuel pressure.
- ➔ **Two Speeds** using tachometer generator signals. These are used for gas-generator speed (N1) and propeller speed (N2).
- ➔ **Four Fuel Quantities** using any variety of either frequency based, voltage based or resistance based quantity probes.
- ➔ **One Fuel Flow** using industry standard pulse / frequency based flow sensors providing both flow rate as well as totalizing capability.
- ➔ **One Battery Voltage and Current** using a 50mV shunt. Measures current in both directions.
- ➔ **Eight Annunciation Switch Inputs** that can measure various conditions. On the Walter turbine they can be used for ISOL, EHT, Hydraulic Pump, Low Oil Press, Beta (propeller), Forward and Aft Chip detects as well as Gen Fail annunciation.

The EIU provides separate and independent power to each sensor requiring external excitation. This prevents any single sensor (or wiring) failure causing the loss of more sensor measurements, which can be found on systems employing a common sensor power bus.

The EIU limits current to each sensor in order to contain possible faults. Such faults whether caused by a bad sensor or faulty wiring are also detected and reported by the EIU.

Electrical connections are made through only one 50-pin standard d-sub connector on the side of the unit. Then through a Windows based program the unit gets configured, calibrated and verified.

Calibration (or mapping) of each of the four fuel tanks are done in one operation – filling an empty tank in stages at user fuel increments until full. Afterward you can, at any time, make small adjustments to any tank's calibration table should you want to.

Three Temperatures

The EIU is able to measure temperatures ranging between -60°C and $+1100$ degrees Celsius using standard K-type thermocouple probes. Thermocouples used for measuring turbine temperature (such as ITT) are normally supplied with an engine, but thermocouples used for Oil-temperature and OAT may need to be obtained separately.

Three Pressures

The EIU reads pressures using standard 4-20mA transducers. This type simplifies wiring by only requiring 2 wires – signal (power) & ground (return) – for each sensor instead of the typical 3 or 4 wires per sensor. They also provide excellent performance in noisy environments. These sensors are commercial off-the-shelf items that can be obtained in various pressure ranges.

Two Speeds

Both the gas-generator speed (N1) and the propeller speed (N2) can be measured by the EIU. Tachometer-Generators provide signals in a fixed frequency-to-speed ratio and are normally supplied with its engine.

One Fuel Flow

Fuel flow sensors normally provide a fixed number of pulses per volume of fuel, called the K-factor. These pulse or frequency based flow sensors can be read by the EIU to not only provide the flow rate, but keep track of the total volume (gallons) of fuel that passed through the sensor.

Four Fuel Quantities

The EIU can measure up to four fuel tank quantities using any combination of frequency-, voltage- or resistance based fuel level probes.

One Voltage and Current

Both the aircraft battery's voltage and current can be measured by the EIU with the use of a high current shunt on the 28Vdc electrical bus. Shunts with various ratings can be used and the EIU even reads reverse current through the shunt, which may be used to measure the current to the starter.

Eight Annunciation Switches

The EIU can detect 5 grounding switches as well as 3 positive (B+) switches. On the Walter turbine they are divided as follows:

- ➔ Negative (grounded) detection - Oil Press, Beta (propeller), Forward and Aft Chip detects and Gen Fail.
- ➔ Positive detection - ISOL, EHT, Hydraulic Pump.

Serial Protocol

RS-232 settings:

Baud Rate:	9600
Data bits:	8
Stop bits:	1
Parity:	None
Stream Repeat Rate:	10 Hz

Data stream description:

Byte Number	Description	Bits Used	Format	Min	Max	Resolution	Units
1-2	MSG Header (ID)	16	0xAB55	N/A	N/A		N/A
3-4	Oil Temperature	16	Signed	-60	1100	1	°C
5-6	Oil Pressure	16	*Unsigned	0	100	0.1	PSI
7-8	Fuel Pressure	16	*Unsigned	0	100	0.1	PSI
9-10	Fuel Flow	16	*Unsigned	0	300	0.1	GPH
11-12	Fuel Used	16	Unsigned	0	N/A	0.01	Gal
13-14	Fuel Level 1 (L)	16	*Unsigned	0	N/A	0.1	Gal
15-16	Fuel Level 2 (C)	16	*Unsigned	0	N/A	0.1	Gal
17-18	Fuel Level 3 (R)	16	*Unsigned	0	N/A	0.1	Gal
19-20	Fuel Level 4 (H)	16	*Unsigned	0	N/A	0.1	Gal
21-22	OAT	16	Signed	-60	1100	1	°C
23-24	Voltage	16	Unsigned	0	50	0.1	Volt
25-26	Current	16	Signed	-1500	1500	0.1	Ampere
27-28	N1/gas-gen speed	16	Unsigned	0	150	0.1	%
29-30	N2/prop speed	16	Unsigned	0	3000	1	RPM
31-32	Torque	16	*Unsigned	0	300	0.1	PSI
33-34	ITT	16	Signed	-60	1100	1	°C
35	Switches	8	See Table Below				
36	Mode	8	See Table Below				
37	Check-sum	8	See Section Below				

Multiple byte values are serialized into single bytes from “high” to “low”, also known as big-endian byte order. Unsigned formats marked with (*) have the following reserved values:

Hex Value	Description	Explanation
0xFFFF	N/CON (not connected)	Sensor is not connected / installed. The EIU can detect the presence of certain sensors (eg pressures).
0xFFFE	N/CAL (not calibrated)	Sensor is not calibrated / mapped (eg. fuel quantities). Also when a fuel quantity (eg. 4 th fuel tank) is not in use.
0xFFFD	FAULT (sensor fault)	A fault is detected with this sensor or with the sensors wiring.

Switches (Annunciation Lights):

Bit Number	Description	Explanation
0	ISOL	Fuel Control Unit is Isolated (emergency valve)
1	EHT	Fuel Limiting active (EHT valve)
2	H-PUMP	Hydraulic Pump active
3	BETA	Propeller is in Beta mode
4	GEN	Generator offline
5	FWD CHIP	Forward Chip Detect
6	AFT CHIP	Aft Chip Detect
7	OIL PRESS	Oil Pressure Low switch

Mode:

Value	Description	Explanation
0	System Initialization	Data is not valid while initializing
1	System Calibration	System in calibration mode
2	System OK	System data valid
3	System Invalid	System data is not valid

Check-sum:

The check-sum is sum of all packet bytes excluding the header and check-sum.

Installation

Tools and Equipment

Tools and equipment required for installation (not included in the purchase) are:

- ✓ Wire cutters
- ✓ Wire strippers
- ✓ Wire (single core, Teflon insulated 20-24 AWG)
- ✓ Thermocouple wire (K-type)
- ✓ A laptop computer or PC running Windows. If not equipped with a serial port, a USB port together with a USB-to-serial adapter will be needed.
- ✓ A standard RS-232 cable (DB-9 male to DB-9 female) may be needed
- ✓ The following sensors (if you want the particular parameter):
 - ➔ Torque pressure sensor
 - ➔ Oil pressure sensor
 - ➔ Fuel pressure sensor
 - ➔ Fuel flow sensor
 - ➔ Fuel level (quantity) probes
 - ➔ Oil temperature sensor
 - ➔ OAT sensor
 - ➔ Current sensing shunt
- ✓ Connector crimp tool
- ✓ DSUB-50 female connector with crimp pins

Description	Part Numbers		
Crimp contacts	M24308/10-1	M39029/63-368	AMP 205090-1
Crimp tool	M22520/2-01	AFM8 (DMC)	
Crimp tool positioner	M22520/2-08	K13-1 (DMC)	
Insertion tool	MS1969/1-02	DAK 145	
Extraction tool	MS1969/1-02	DAK 145	

Electrical Installation

The following section describes the wiring requirements for using the EIU. Please follow these instructions explicitly as improper wiring can result in permanent damage to your unit. All electrical power and data lines interface with the EIU via the 50-pin D-Sub connector on the side of the unit.

Recommended wiring practices

NOTE: For all electrical connections, use correct splicing techniques, taking care to properly insulate any exposed wire. A short circuit between any of the wires may cause damage to the EIU and/or other equipment.

VR Avionics does not normally supply connectors or wire for wiring up your EIU. We recommend that standard aircraft grade wiring and connectors be used during installation. Gauges 20 through 24 AWG wire is sufficient for most lines to the unit. Make sure you protect the power lines with either a circuit breaker or fuse sized appropriate to the wire you select. We recommend you use wire meeting Mil Standard MIL-W-22759/16 (Tefzel insulation) which is available from various suppliers. Another option is to use Teflon insulated wire which is available in various colors.

Connectors: We recommend you use machined pin connectors to mate with the EIU connector. Crimp connections have proven to be the most reliable in aircraft installations. D sub shells to hold the pins are available from various sources. Purchasing quality connectors is a very wise investment.

Installing: Make sure all connections are secure and all wires are routed and strain relieved to ensure the wires will not chafe against any other object in the aircraft.

Electrical installation of the EIU system is divided in sections according to function:

- ◆ [Power, ground and serial output](#)
- ◆ [Voltage and current sensing](#)
- ◆ [Fuel quantities sensing](#)
- ◆ [Fuel flow sensing](#)
- ◆ [Temperatures sensing](#)
- ◆ [Pressures sensing](#)
- ◆ [Speeds sensing](#)
- ◆ [Annunciation switches sensing](#)

Power, Ground and Serial Output

The EIU's power, ground and serial output hookup is as shown below. A circuit-breaker rating of 2 Amp is more than sufficient.

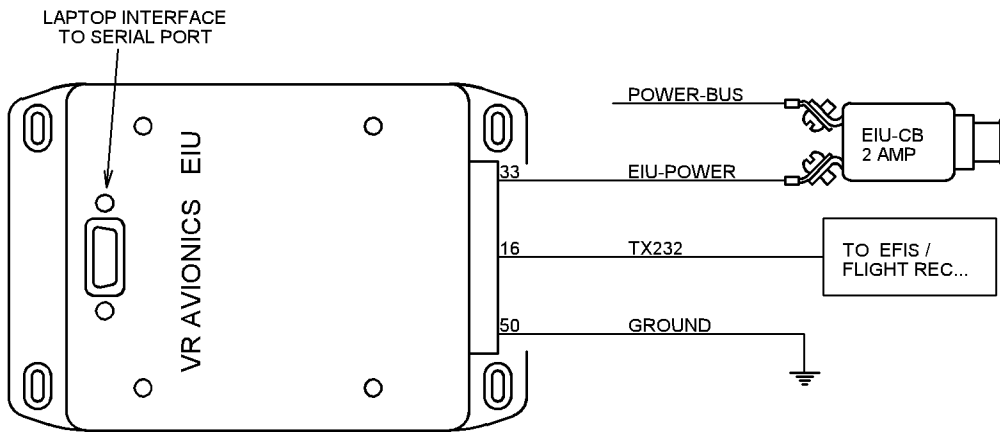

Voltage and Current Sensing

The EIU measures both voltage (volts) and current (amps) through 2 wires as shown below. Both wires need to be protected by fuses mounted close to the shunt. The EIU reads 50mV shunts – shunts that produce 50mV at their rated current. The EIU can be configured for shunts rated up to and including 500 Amp.

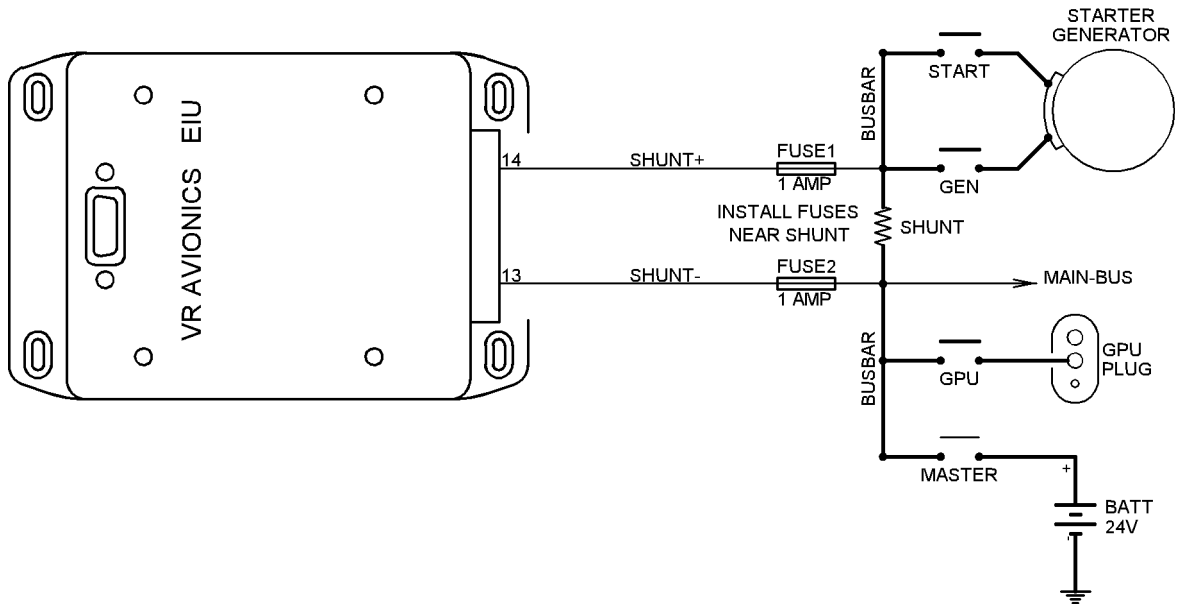

The diagram above shows one possible location of the shunt. In this arrangement it can read both starting current and generator current. Remember to set the **Shunt Rating** configuration property to the value of the shunt you use.

Below are a few shunt examples:

Manufacturer	Part Number	Shunt Rating
Electronics International	S-300	300 A
Murata Power Solutions	3020-01102-0	300 A
TE Connectivity / Crompton	FN-300-50	300 A
Murata Power Solutions	3020-01103-0	500 A

Fuel Quantities

The EIU can measure 4 fuel quantities using any combination of the following sensors / probes:

- ➔ 5 volt powered frequency output sensor
- ➔ 5 volt powered 0 to 5 volt output sensor
- ➔ Resistive – float type senders (0 – 270 ohm)
- ➔ 12 volt powered frequency output sensor
- ➔ 12 volt powered 0 to 5 volt output sensor

Basic fuel quantity probe connections are shown below.

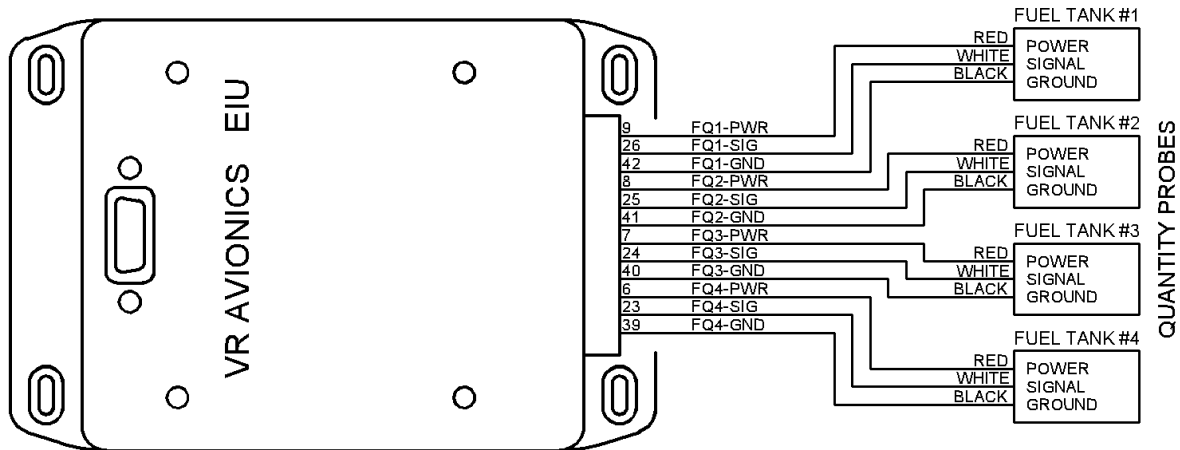

RESISTIVE PROBES REQUIRE ONLY SIGNAL & GROUND WIRES



Resistive fuel probes use only 2 wires – signal (SIG) and ground (GND) as shown above. The EIU senses resistances from 0 up to a maximum of 270 ohms.

When using frequency based sensors from Electronics International you do not require the divide-by-4-circuit some of their measuring units require between the probe and the measuring unit. Our EIU is able to measure probe frequencies up to 60 KHz directly.

Calibration of fuel levels are covered in [Calibrating Fuel Tank Levels](#) discussed later in this manual.

The following are a few fuel level probe examples:

Manufacturer	Probe Type	Part Number
Electronics International	5 volt powered frequency output	P-300C
Westach	12 volt powered voltage output	395-5SB-5
Westach	Resistive (240 – 30 ohm)	395-5T

Fuel Flow

The EIU reads an open collector pulse based fuel flow sensor, which is an industry standard. The EIU also provides the sensor with power (12V excitation). Fuel flow hookup is as shown below.

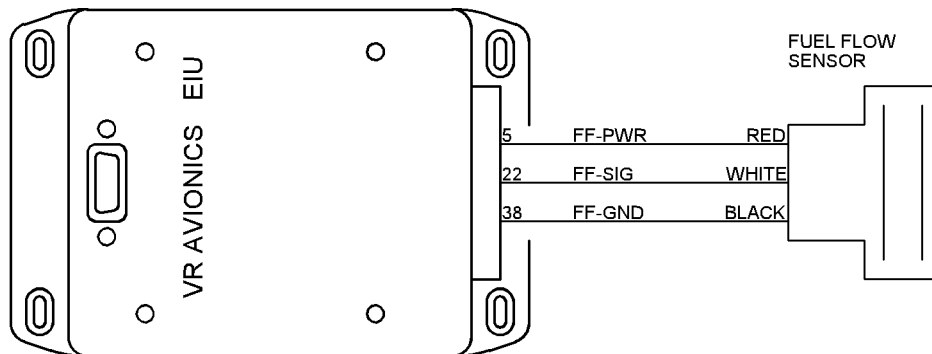

Any open collector pulse (frequency) based fuel flow sensor will work. A lot of customers however opt for the FT-180 “black cube” from Electronics International.

Remember to set the **Fuel Flow K-factor** configuration property to the k-factor value that comes with your fuel flow sensor.

Temperatures

The EIU can measure 3 temperatures using standard k-type thermocouple probes. The diagram below shows the hookup to these probes.

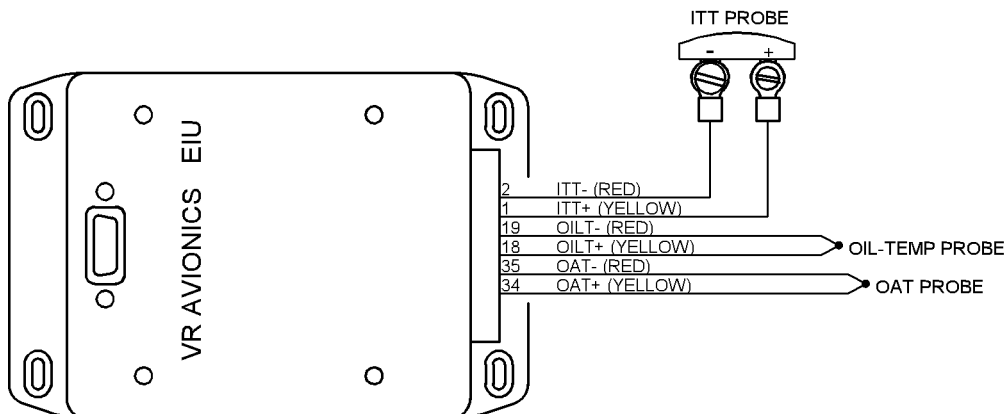

Below are a few oil temperature probe examples:

Manufacturer	Part Number
Electronics International	P-120
J.P.I Instruments	400509
UMA Instruments	T3B3

And a few OAT probe examples:

Manufacturer	Part Number
Electronics International	P-128
J.P.I Instruments	400510

Pressures

The EIU can measure three pressures using 4-20mA transducers as shown below:

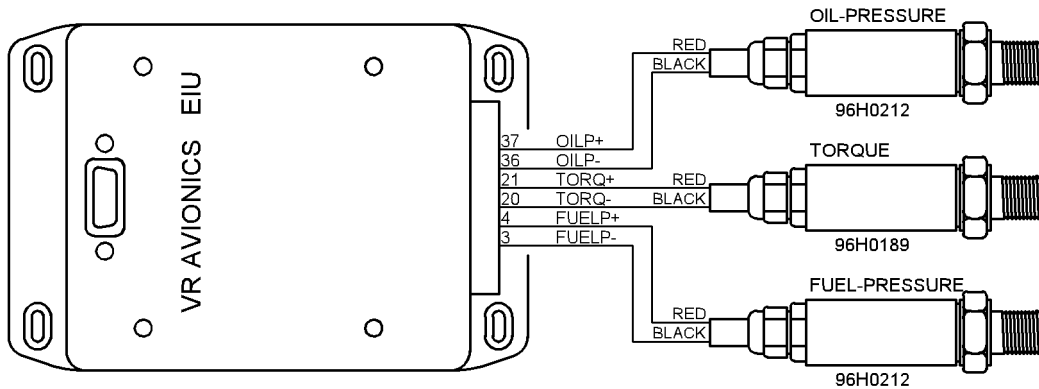

A wide range of 4-20mA pressure sensors (with various port sizes, pressure ranges, etc.) are available commercially off-the-shelf. The EIU must be configured for each sensor it reads – it must know the pressure range (rating). The relevant configuration settings are [P1 Pressure Transducer Rating](#), [P2 Pressure Transducer Rating](#) and [P3 Pressure Transducer Rating](#). Below are a few sensor examples:

Measurement (M601 engine)	Manufacturer	Part Number	Typical Sensor	
			Press. Range	Rating Setting
Torque (0 – 200 psi minimum)	MSI	M5151-000005-250PG	0 - 250 psi	2500
	Honeywell	MLH200PGM06B	0 - 200 psi	2000
	SSI Tech	P51-200-G-A-I36-20MA-000-000	0 - 200 psi	2000
Oil-pressure & Fuel pressure (0 – 50 psi minimum)	MSI	M5151-000005-050PG	0 - 50 psi	500
	Honeywell	MLH100PGL01B	0 - 100 psi	1000
	SSI Tech	P51-50-G-A-I36-20MA-000-000	0 - 50 psi	500

If you use a TSLM unit, you can share the torque and oil-pressure sensors between these units as shown below:

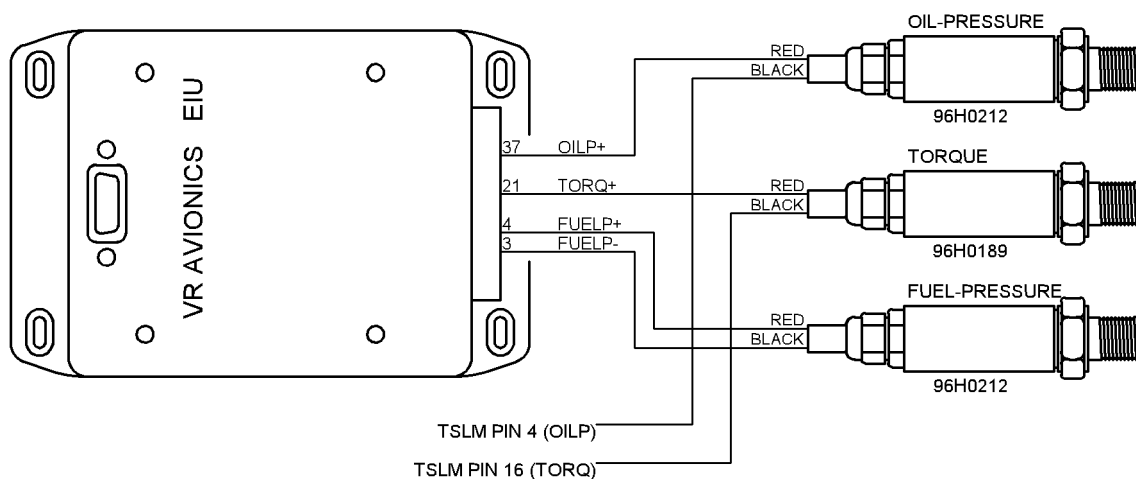

A single set of torque and oil-pressure sensors can thus be used by both the EIU and the TSLM. Note that the EIU provides excitation for these sensors – a voltage close to the 28 volt supply input will be present here. If for example one pulls the EIU circuit-breaker, both these readings will become unavailable for the TSLM also.

Speeds

The EIU can detect tachometer-generator signals to measure at least two speeds. The figure below shows the hookup to a Walter turbine's N1 and N2 tachometer-generators.

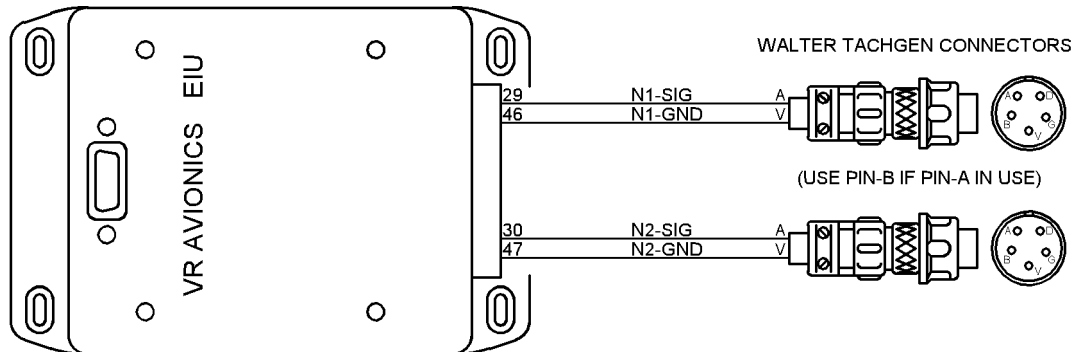

Ensure both the [N1 Speed Calibration](#) and [N2 Speed Calibration](#) configuration properties are set to their correct values for the M601 engine. See the relevant configuration properties discussed later in this manual.

Annunciation Switches

The EIU can detect 8 switch inputs which may be used to drive annunciation lights on an attached VRX multi-function display or 3rd party EFIS screen. Three positive switching (pins 10, 27, 43) and 5 negative (ground) switching (pins 45, 11, 28, 12, 44) sensors can be connected.

The figure below shows a typical installation for the Walter engine:

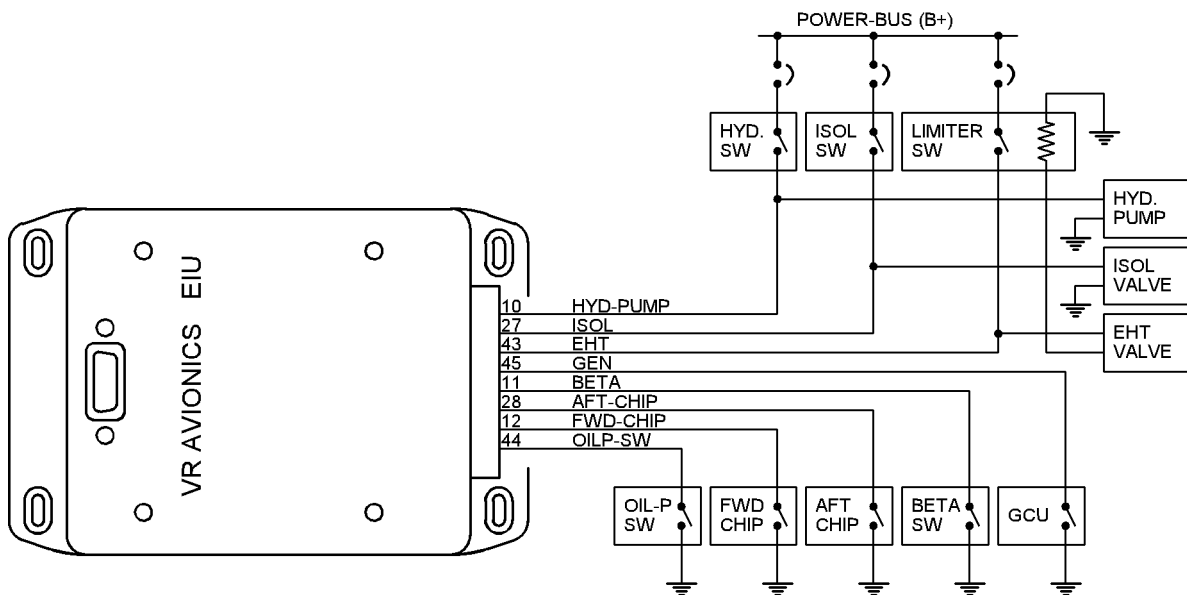

Inputs may be wired to sense something else altogether. The VRX display and/or EFIS screen will however need to be reconfigured accordingly in order to indicate the correct warning or caution text for example.

Pin Assignments

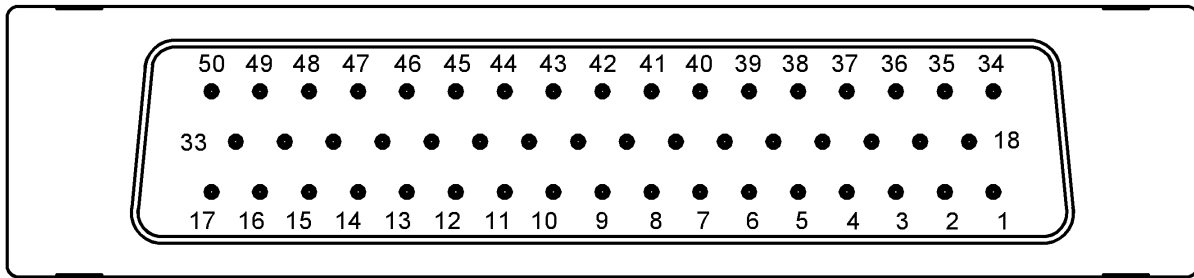

PIN	DESC	PIN	DESC	PIN	DESC
1	ITT+	18	OILT+	34	OAT+
2	ITT-	19	OILT-	35	OAT-
3	FUELP-	20	TORQ-	36	OILP-
4	FUELP+	21	TORQ+	37	OILP+
5	FF-PWR	22	FF-SIG	38	FF-GND
6	FQ4-PWR	23	FQ4-SIG	39	FQ4-GND
7	FQ3-PWR	24	FQ3-SIG	40	FQ3-GND
8	FQ2-PWR	25	FQ2-SIG	41	FQ2-GND
9	FQ1-PWR	26	FQ1-SIG	42	FQ1-GND
10	HYD-PUMP	27	ISOL	43	EHT
11	BETA	28	AFT-CHIP	44	OILP-SW
12	FWD-CHIP	29	N1-SIG	45	GEN
13	SHUNT-	30	N2-SIG	46	N1-GND
14	SHUNT+	31	CAN-L	47	N2-GND
15	CAN-T	32	CAN-L	48	CAN-H
16	TX232	33	PWR	49	CAN-H
17	RX232			50	GND

Configuration

Introduction

This chapter describes the configuration settings of the EIU, which can be accessed in one of two ways, either:

- 1) through a Windows computer running our SetView software, or
- 2) through a VRX multi-function display.

See the [SetView Software](#) chapter later in this manual about how to do it through your Windows computer / laptop.

The VRX–M601 Operational & Installation manual (which can be downloaded from our website) describes how to do it through the VRX multi-function display.

Configuration Settings

In this section we describe the various configuration properties of the EIU. See [Adjusting the Configuration](#) about how to alter any of these settings.

Temperature Calibration Offset

This setting is unique to a particular EIU. It calibrates the **offsets** (or zero points) of all three temperature readings. Good practice is to remember what this setting was before changing it.

Temperature Calibration Span

This setting is unique to a particular EIU. It calibrates the **spans** (or amplification factors) of all three temperature inputs. Good practice is to remember what this setting was before changing it.

Voltage Calibration

This setting is unique to a particular EIU. It calibrates the voltage input.

Shunt Rating

This setting selects your particular shunt (rating). It is the current (amps) where 50mV gets measured across the shunt. For a 300 amp shunt set this to 300.

Shunt Positive Current Calibration

This setting is unique to a particular EIU. It calibrates the Amps input in the positive direction. Before changing it ensure the [Shunt Rating](#) is set correctly and the expected reading is still off. Also good practice is to always remember what this setting was before.

Shunt Negative Current Calibration

This setting is unique to a particular EIU. It calibrates the Amps input in the negative direction. Before changing it ensure the [Shunt Rating](#) is set correctly and the expected reading is still off. Also good practice is to always remember what this setting was before.

P1 Pressure Transducer Rating

This setting selects the sensor type (or rating) used for the torque measurement. For example, set to 2500 if using a 0 – 250 psi sensor.

P1 Pressure Calibration

This setting is unique to a particular EIU. It calibrates the 4-20mA torque sensing input. Before changing it make sure the P1 Pressure Transducer Rating is set correctly and the expected reading is still off. Also good practice is to always remember what this setting was before.

P2 Pressure Transducer Rating

This setting selects the sensor (rating) for the oil-pressure measurement. For example, set to 500 if using a 0 – 50 psi sensor.

P2 Pressure Calibration

This setting is unique to a particular EIU. It calibrates the 4-20mA oil-pressure sensing input. Before changing it make sure the P2 Pressure Transducer Rating is set correctly and the expected reading is still off. Also good practice is to always remember what this setting was before.

P3 Pressure Transducer Rating

This setting selects the sensor (rating) for the fuel pressure measurement. For example, set to 500 if using a 0 – 50 psi sensor.

P3 Pressure Calibration

This setting is unique to a particular EIU. It calibrates the 4-20mA fuel pressure sensing input. Before changing it make sure the P3 Pressure Transducer Rating is set correctly and the expected reading is still off. Also good practice is to always remember what this setting was before.

N1 Speed Calibration

This setting must be set to 14263 for the M601 engine's normal N1 tachometer-generator.

N2 Speed Calibration

This setting must be set to 29574 for the M601 engine's normal N2 tachometer-generator.

Fuel Flow K-factor

This setting adjusts the k-factor of your fuel flow sensor. The k-factor is the number of pulses your sensor sends out for every one US gallon that flows through it.

Fuel Flow Filter Setting

This setting adjusts the response of the fuel flow reading - from 0 to 15. The higher the number, the more filtering is applied, the slower the response.

Fuel Flow Sensor Type

Must be set to 2. It selects 12V excitation for the fuel flow sensor. This setting is only visible on units with older firmware versions.

Fuel Level x Sensor Type

The table below shows the fuel level / quantity probe types supported and their available settings:

Sensor Type setting	Description
0	Not used
1	5 volt excitation frequency probe
2	5 volt excitation analog (0 – 5V) voltage probe
3	Resistance probe (0 – 270 ohm)
4	12 volt excitation frequency probe
5	12 volt excitation analog voltage probe

Fuel Level x Calibration Offset, Interval and last interval

These three configuration settings define the 20 fuel levels (US gallons, liters, etc.) that are represented by the 20 calibration points allocated for each tank. They are automatically filled in by SetView when you perform a fuel tank calibration operation.

Fuel Level x Calib point	Formula	Example: Offset:20, Interval:25, last interval:10
1	Offset	2.0 (gallons)
2	Offset + (1 x Interval)	4.5 (gallons)
3	Offset + (2 x Interval)	7.0 (gallons)
4	Offset + (3 x Interval)	9.5 (gallons)
5	Offset + (4 x Interval)	12.0 (gallons)
6	Offset + (5 x Interval)	14.5 (gallons)
7	Offset + (6 x Interval)	17.0 (gallons)
8	Offset + (7 x Interval)	19.5 (gallons)
9	Offset + (8 x Interval)	22.0 (gallons)
10	Offset + (9 x Interval)	24.5 (gallons)
11	Offset + (10 x Interval)	27.0 (gallons)
12	Offset + (11 x Interval)	29.5 (gallons)
13	Offset + (12 x Interval)	32.0 (gallons)
14	Offset + (13 x Interval)	34.5 (gallons)
15	Offset + (14 x Interval)	37.0 (gallons)
16	Offset + (15 x Interval)	39.5 (gallons)
17	Offset + (16 x Interval)	42.0 (gallons)
18	Offset + (17 x Interval)	44.5 (gallons)
19	Offset + (18 x Interval)	47.0 (gallons)
20	Offset + (18 x Interval) + Last Interval	48.0 (gallons) – full tank

Fuel Level x Calibration Points

These are the sensor values (representing frequency, voltage or resistance) at each of the 20 (gallon) points in the previous paragraph. This constitute the calibration table for each fuel tank, which provides more accurate fuel levels readings for fuel tanks of various shapes.

These 20 calibration points are automatically filled into by SetView when you perform a fuel tank calibration operation. Thereafter you can make minor adjustments here should you wish to.

Fuel Level Designation RS232

This setting allows you to re-designate the 4 fuel levels / quantities between input pins and RS232 serial output to EFIS. Typically it is set to 1234, but you can change the order it goes to the EFIS.

Input from probe	Output to EFIS / VRX	
	Typical (setting = 1234)	Example (setting = 3214)
FQ1 (pins 9, 26, 42)	1	3
FQ2 (pins 8, 25, 41)	2	2
FQ3 (pins 7, 24, 40)	3	1
FQ4 (pins 6, 23, 39)	4	4

SetView Software

Introduction

The SetView software connects to the EIU and allows you to do the following:

- ➔ Update firmware
- ➔ View and record parameters
- ➔ View and adjust configuration / settings
- ➔ Share configuration and recordings via email
- ➔ Calibrate / map fuel tank levels

System Requirements

- ➔ Operating System: Windows 7 or higher
- ➔ One available serial port. If no serial port is available, a USB port together with a USB-to-Serial Converter can be used.

SetView download and Installation

Find the latest version of SetView on our website (www.vravionics.com) and install it onto your Windows computer or laptop:

- ➔ Click on the **SetView Software** link found at (www.vravionics.com/downloads.html)
- ➔ Click on **Install** and run the setup.exe until all is successfully installed.

Bundled with the latest software are the latest firmware for all VR units in your system (EIU, TSLM, PDC, FSM, etc.). This new firmware may provide new features or have corrected old problems.

Using SetView

Through its dedicated 9 pin maintenance connector the EIU can link with your computer / laptop connecting either directly to your computer's serial port or via a USB-to-Serial converter.

- ➔ Plug in your USB-to-Serial converter (if you are using one) in your Laptop. If this is the first time it have been plugged into a specific USB port, wait for Windows to recognize it and successfully install its driver.
- ➔ Connect the USB-to-Serial converter serial port to the 9 pin maintenance connector.
- ➔ Run the SetView Software.
- ➔ Select from the main menu System > Serial Port. Confirm you have a COM port selected and that it is the right one.
- ➔ Power the EIU module (by switching on the aircraft's master switch).

Reasons for failing to establish communication could be:

- ➔ Power was not applied to the EIU, or
- ➔ The serial cable between the unit and the laptop is not connected properly, or
- ➔ The correct serial port was not selected, or
- ➔ The USB-to-Serial converter driver was not properly installed. If you have bought a new USB-to-Serial converter, you first need to get it to work with Windows on your computer. Plug only the USB-to-Serial converter into the laptop / PC, let Windows recognize it and install the relevant driver first. Only when this is complete and Windows tells you that the device is ready to be used, should you plug it into the EIU, start the SetView software and switch the power on.

Viewing and recording parameters

After running the SetView software, selecting the correct serial port and applying power to the system, the SetView software should start showing the following parameters:

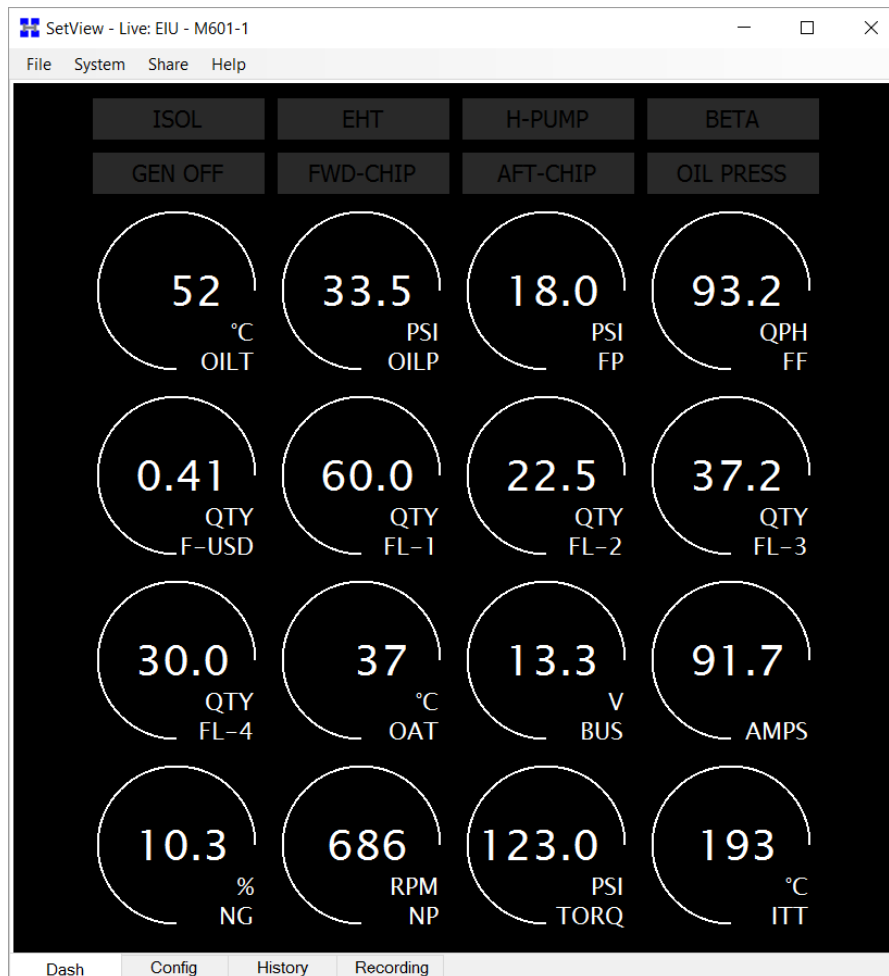

To **make a recording** select from the main menu System > Record Parameter Stream. To stop recording thereafter select System > Stop Recording Parameter Stream. The recording will then be saved to a file and shown in graph format for you to view.

Synchronizing with the system

By synchronizing (menu > system > synchronize) SetView will first check the firmware version of the EIU and any other VR units in your system (connected via CAN bus). If there is a new version SetView will in each case ask you if you want to update. Only if you select Yes it will update the particular unit to the new version.

A synchronize will also make SetView read the EIU's configuration as well as those for the other VR units in your system. The bundled configuration settings will be saved to file and can be viewed by simply clicking on the **Config** tab at the bottom of SetView.

Sharing files via email

If you have made a recording and/or done a synchronize which will read the EIU configuration, you can easily share these files with others via email (menu > Share). If troubleshooting and you require support from VR Avionics, you may email your recording and configuration to us so we can better be able to assist you.

Adjusting the Configuration

To make adjustments to the configuration (such as setting the [Fuel Flow K-factor](#)), select from the main menu **System > Adjust Configuration...** The system will take a second or two to first read the configuration settings before allowing you to adjust them.

Model	Serial #	Configuration Property	Setting	Access
EIU	1234	Voltage Calibration	544	Adjustable
EIU	1234	Shunt Rating	300	Adjustable
EIU	1234	Shunt Positive Current Calibration	3300	Adjustable
EIU	1234	Shunt Negative Current Calibration	15400	Adjustable
EIU	1234	P1 Pressure Transducer Rating	2000	Adjustable
EIU	1234	P1 Pressure Calibration	9640	Adjustable
EIU	1234	P2 Pressure Transducer Rating	500	Adjustable
EIU	1234	P2 Pressure Calibration	9700	Adjustable
EIU	1234	P3 Pressure Transducer Rating	500	Adjustable
EIU	1234	P3 Pressure Calibration	9700	Adjustable
EIU	1234	N1 Speed Calibration	14263	Adjustable
EIU	1234	N2 Speed Calibration	29574	Adjustable
EIU	1234	Fuel Flow K-Factor (pulses per gal)	13210	Adjustable
EIU	1234	Fuel Flow Filter Setting	10	Adjustable
EIU	1234	Fuel Level 1 Sensor Type	1	Adjustable

To modify any specific configuration item, scroll to the item and hit <SPACE BAR> or double-click on it. A dialog box will appear where you can assign a new value to that configuration property...

Fuel Flow K-Factor (pulses per gal)

13210

Update

Cancel

When done click the Update button to change the configuration item setting.

Calibrating Fuel Tank Levels

We describe how to calibrate the EIU fuel levels using the SetView software. Calibration may also be done via a VRX MFD and is described in the relevant VRX Operational and Install Manual.

To calibrate (or map) a fuel tank using SetView you must first set its sensor type. You do this by adjusting the [Fuel Level x Sensor Type](#) configuration setting.

Then select from the main menu **System > Diagnostic Function > MAP FL-1** (or FL-2, FL-3, FL-4 depending on the fuel tank you want to map). The screen below shows mapping for FL-2.

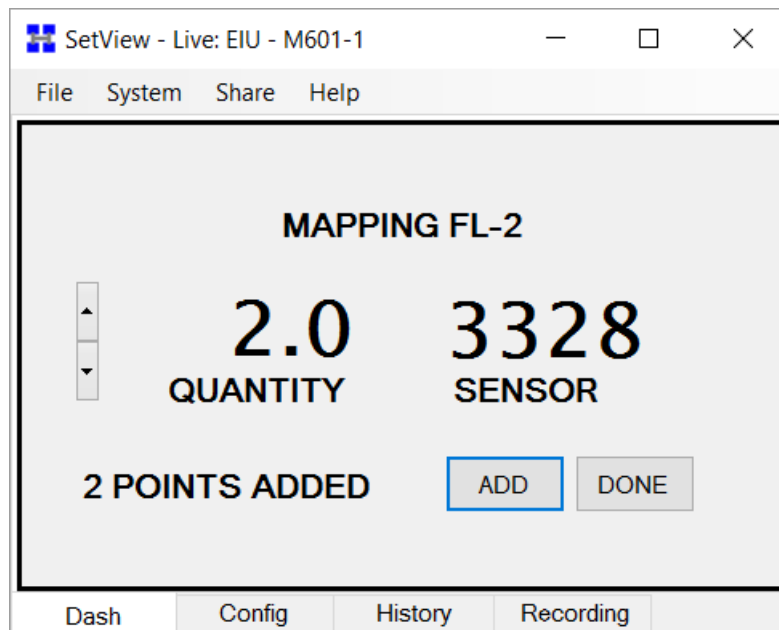

Also on the screen are three values. On the left is the QUANTITY value, on the right the SENSOR value / reading, and below in the middle the total POINTS ADDED value.

1. Starting with an empty tank fill it to the lowest amount you want displayed. This can be an empty tank if you wish. Use the UP and DOWN arrows on the left to set the QUANTITY value to the amount you have poured in.
2. Press the ADD button when the SENSOR reading has stabilized to add this point. You'll see the POINTS ADDED increment to indicate that the point was added to the internal mapping table.
3. Repeat by pouring another amount of fuel into the tank, setting the QUANTITY value, and then adding that point to the internal mapping table. Note that there is 50 points available in the table so make sure you don't make the fuel increments too small and exhaust the 50 spots before you reach a full tank.
4. When the fuel tank reaches it's full value, enter and ADD this last point to the table, then select the DONE button.
5. You'll be prompted on whether you want to proceed and write the calibration table, YES or NO. Select YES to complete the process or NO to cancel out back to the main menu.